

technical hotline +44 (0)1268 563720

screeded floor systems

Onix Plus™ Floorboxes

Onix Plus™ Floorboxes and Power Grommets are a unique, innovative solution to hard floor power and data distribution requirements in screed floors with coverings such as laminate, wood, stone and marble.

- Wet washable and IP44 when not in use
- Tested to EN50085-2-2 to accept 10,000N load
- Selection of lid recess depths available, allowing for various floor depths
- Designed to support Cat 6 structured cabling systems
- Wide range of power and data accessories available to meet all requirements
- Quality, reliability and safety come as standard
- Provision of RCD protection supports compliance with the 17th Edition Wiring Regulations
- 5 year guarantee

Materials

Round Aluminium Floorbox

Lid and Frame manufactured in die cast aluminium. Snorkel Cord Outlet mouldings are manufactured from a UL94 V2 rated nylon.

Box Lid and Frames

Lid, load plate and frame manufactured in stainless steel. Cord Outlet mouldings are manufactured from a UL94 V2 rated nylon.

Power Grommet

Service outlet is die cast and forged aluminium, zinc, bronze and stainless steel. The base unit is pre-galvanised steel. Plastic parts are polycarbonate.

RAL Colours

Grey (GRY) = RAL 7011

Light Grey (LGY) = RAL 7046

Beige (BGE) = RAL 1019

Lid Recess Dimensions

The dimensions in the table provide the sizes for the floor covering insert for the lid.

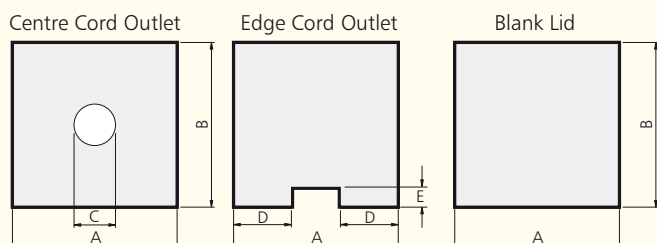

Box size	Dimension (mm)				
	A	B	C	D	E
200x200mm	189	189	102	35.5	43
265x265mm	252.5	252.5	102	67.5	43
340x340mm	329	329	102	105.5	43

Note: Due to the weight of the lid and floor covering, a tile lifter, not the cord outlets, should be used to lift these lids.

Wet Wash Test

The plain lid and the centre Snorkel outlet lids have an Ingress Protection rating of IP44, according to BS EN60529: 1992

Standards

These products are designed to withstand heavier than normal traffic loading as found in office buildings. The Onix Plus™ range supports compliance with the requirements of the latest edition of the IEE Wiring Regulations (BS 7671) and to BS EN50085 Part 1 and EN50085 Part 2-2. Additionally the floorboxes also comply with IEC 60670 Parts 1 and 23.

Centre Cord Outlet Restrictions

This applies to the Round Aluminium Floorbox and the Box Lid with Snorkel Cord Outlet.

Screed Depth Table – For Snorkel Lid with Flush Accessories

Wiring Space (mm)	Floor Tile Thickness - including adhesive (mm)	Minimum Screed Depth (mm)	Minimum Finished Floor Depth (mm)
25	15	85	100
25	20	80	100
25	25	75	100
25	30	70	100
35	15	95	110
35	20	90	110
35	25	85	110
35	30	80	110
45	15	105	120
45	20	105	120
45	25	95	120
45	30	90	120

- Decide Wiring Space required: 25mm, 35mm or 45mm
- Decided Floor Tile Thickness. (This must align with the lid depth choice)
- Read across to determine the minimum screed depth and subsequent finish floor thickness

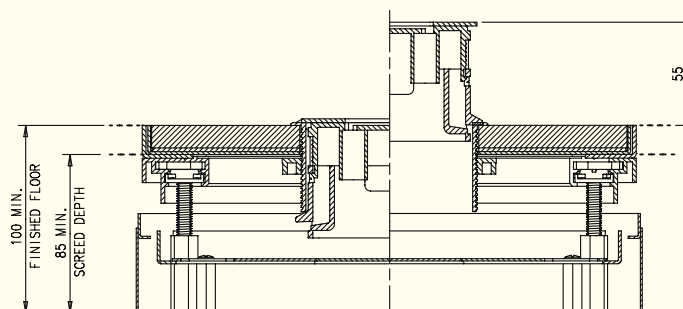

* The Snorkel cord outlet cannot be used in depths less than 100mm.

Onix Plus™ Floorboxes and Power Grommets

Round Aluminium Floorbox Dimensions

This floorbox must be used in conjunction with the 370x370mm Onix Base Unit, 3 compartment (NXB370XUK-3)

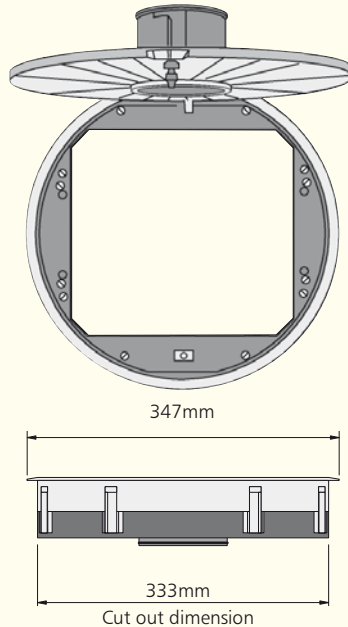

Metal Power Grommet Dimensions

The Metal Power Grommet is designed to be used in conjunction with the Screed Base Unit, part number NXGB100-1 or NXGB100X-1, depending on the depth of the screed.

Onix Grommets are designed to be IP44 rated when the lid is closed, allowing the floor to be washed.

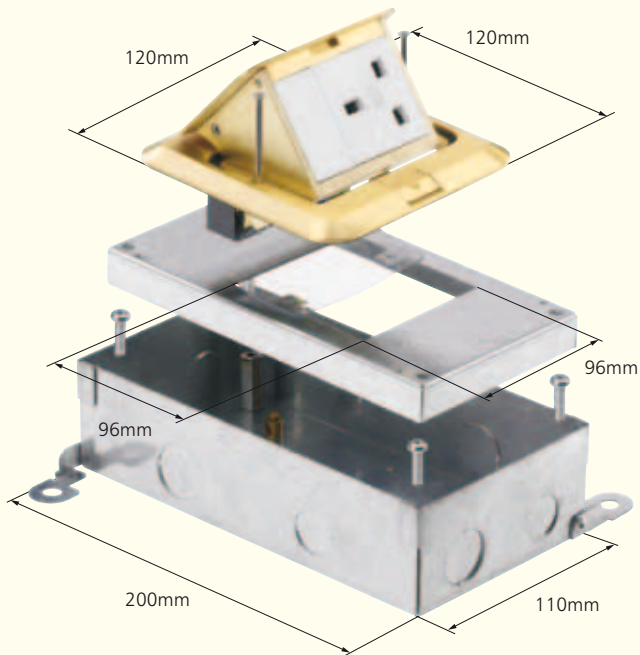

BASE UNIT	NXGB100-1	NXGB100X-1
Screed Depth (mm)	55-80mm	80-110mm

Load Testing

Load Testing of Floorboxes to draft pr EN50085 Part 2-2 (Clauses 10.5.103 and 10.5.104).

The floorboxes have been tested to and comply with the loading requirements of draft pr EN50085 Part 2-2 (Cable trunking systems and cable ducting systems for electrical installations Part 2-2: Particular requirements for cable trunking systems and cable ducting systems intended for mounting underfloor, flushfloor, or onfloor).

There are two loading criteria for the floorboxes - one with a point loading to replicate foot traffic for example, and the other, with a large plate to replicate fork trucks and heavier larger loads for example. For both loading criteria the maximum allowable deflection under load is 6mm and the maximum permanent deflection after the load has been removed is 3mm. The loading position is the centre of the lid.

The Lid Deflection (loading) graph shows that the maximum test wheel loading classification achieved is 3kN and the maximum large plate loading classification achieved is 10kN.

The Permanent Deflection graph shows the permanent deflection from the test wheel loading at 3kN is 0.8mm and large plate loading at 10kN is 1.65mm. This is well within the maximum allowable deflection of 3.0mm.

Note: This test data specifically refers to the 265x265mm sized cord outlet box assembly. The other floorbox sizes also comply with the required test criteria. Declarations of conformity are available on request for the entire range.

Lid Deflection - Onix Plus Cord Outlet Lid 265x265mm

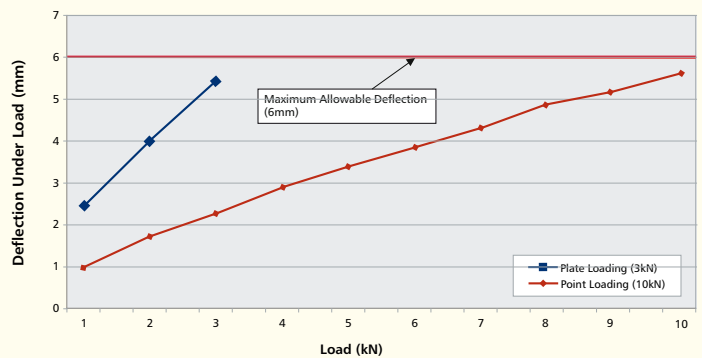

Permanent Deflection After Removal of Load - Onix Plus 265x265mm Cord Cap Lid

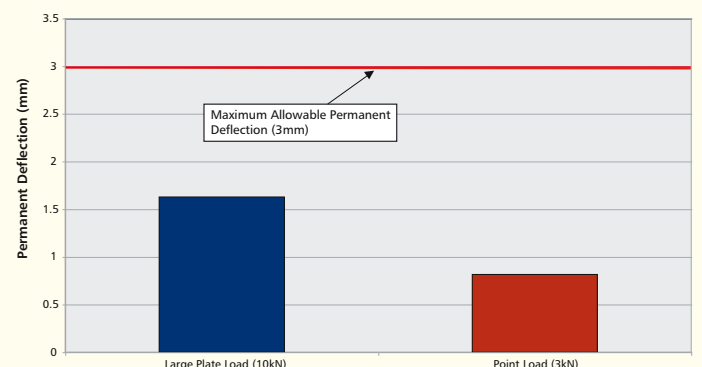

technical hotline +44 (0)1268 563720

screeded floor systems

Onix Plus™ Floorboxes and Power Grommets

Full installation instructions are supplied with the product. Full details of the Onix Plus System can be found on page 49.

Installation of Snorkel Lid and Round Aluminium Floorbox

- ① The base unit is fixed to the slab and the ducts or conduits are fed into the base using the appropriate side entry plate.
- ② The disposable screed cover is fitted to prevent the ingress of screed through the top. All areas of the box which may be susceptible to screed ingress should be sealed.
- ③ The Lid frame should be assembled and fitted after the disposable screed lid has been removed and the gasket can now be fitted.
- ④ The lid is supplied with an earth lead and must be bonded to earth for all power applications. As the lid is only installed when the floor covering is laid there is less chance the surface finish of the lid will be damaged.
- ⑤ A floor covering insert is required for the lid recess. The dimensions for the insert are given in the Lid Recess Dimensions section see page 99.
- ⑥ Sealing compounds are required for products that are for use in wet wash environments.
- ⑦ The bases are supplied with 35mm wiring space, but with the option to reduce to 25mm or increase to 45mm with the Cuba-1 or Cuba-2 height adjustment kit.

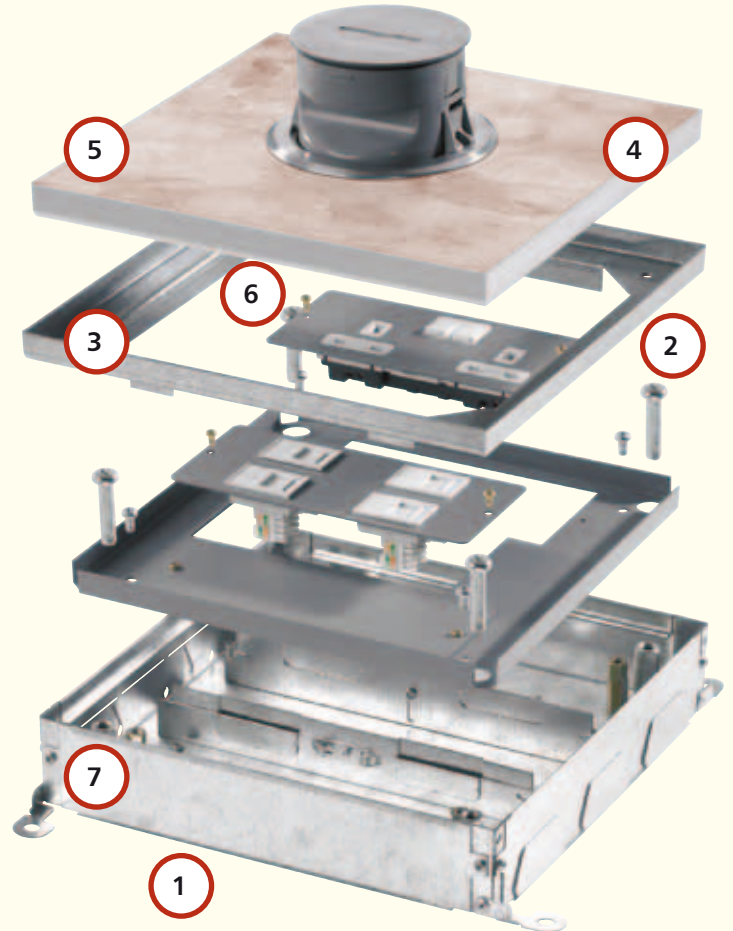

Screed Depth – 25mm, 35mm and 45mm Wiring Space

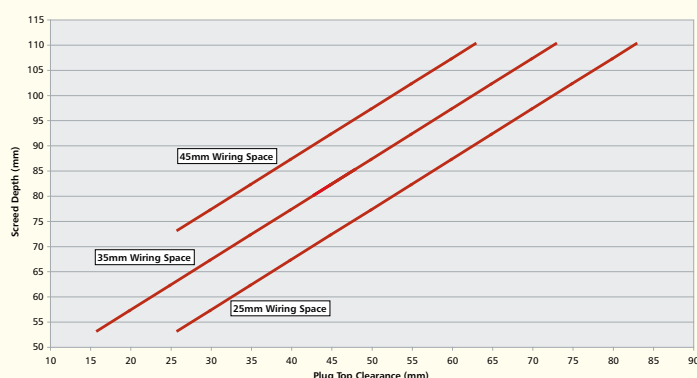

Cat 6 Compatibility

With the introduction of Cat 6 data cabling the orientation and depth of many data outlets has changed resulting in the need for greater backbox depths and wiring space to accommodate these longer data outlet. No longer is a 35mm wiring space sufficient to ensure data terminations can be made to the manufacturer's recommendations to prevent transmission losses. As a result MK has introduced 45mm wiring space for the Cablelink Plus Floorbox systems (as well as for the Prestige 3D wall trunking system). This easily accommodates the longer Cat 6 data outlets and leaves sufficient space for the data cable to run underneath it.

Onix Plus™ Floorboxes and Power Grommets

Installation of Metal Power Grommets

- 1 The Screed Base Unit, is laid onto the concrete slab. There are two Screed Bases available depending on the screed depth.

Screed depth between 55mm and 80mm use NXGB100-1.

Screed depth between 80mm and 110mm use NXGB100X-1.

A metal plate supplied with the Screed Base Unit to keep the screed out of the interior of the box.

After screeding the mounting plate is fitted and the floor covering is laid.

- 2 The grommet top is installed after the floor covering is laid. The lid is simply screwed into position until tight with the floor.

This product is typically installed in areas such as gangways, walkways or light foot traffic areas.

